

No. 675,991.

Patented June 11, 1901.

W. E. WHITE.  
NUT LOCK.

(Application filed Apr. 10, 1901.)

(No Model.)

*Fig. 1.*

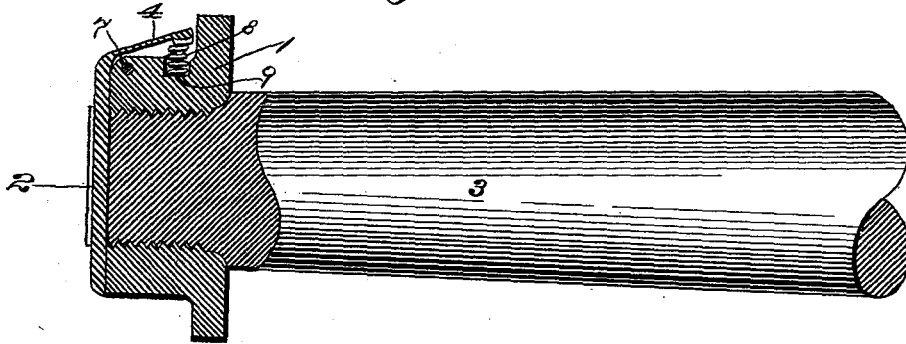

*Fig. 2.*

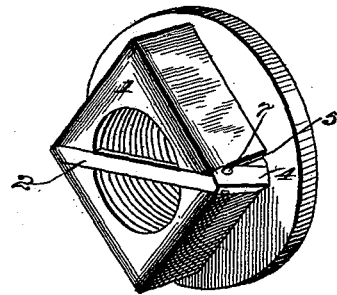
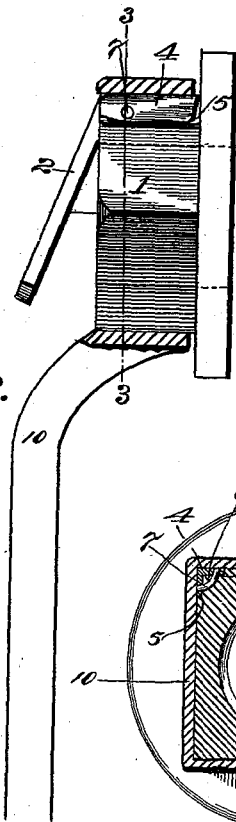

*Fig. 4.*

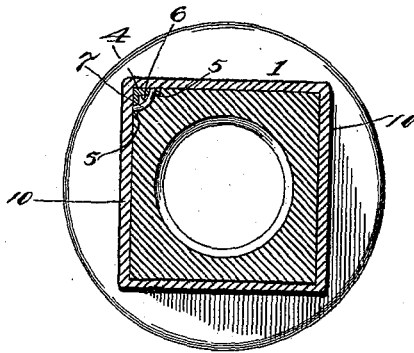

*Fig. 3.*

Witnesses

*Met. E. Maynard.*  
*W. J. Shepard.*

*W. E. White, Inventor.*  
*By C. A. Snow & Co.*  
Attorneys

# UNITED STATES PATENT OFFICE.

WILLIAM E. WHITE, OF POLLOKSVILLE, NORTH CAROLINA.

## NUT-LOCK.

SPECIFICATION forming part of Letters Patent No. 675,991, dated June 11, 1901.

Application filed April 10, 1901. Serial No. 55,225. (No model.)

*To all whom it may concern:*

Be it known that I, WILLIAM E. WHITE, a citizen of the United States, residing at Pollokville, in the county of Jones and State of North Carolina, have invented a new and useful Nut-Lock, of which the following is a specification.

This invention relates to nut-locks, and has for its object to particularly arrange for the locking of hub-attaching devices to the axle-spindles and to provide for the convenient application and removal thereof. It is furthermore designed to arrange the locking mechanism so that the application of a wrench to the nut will throw the locking parts out of their locked positions, whereby the application and removal of a wrench automatically effects the respective unlocking and locking of the nut without particular attention to the locking parts, thereby facilitating the application and removal of the nut, especially in the dark or where it is difficult to carefully examine the nut.

With these and other objects in view the present invention consists in the combination and arrangement of parts, as will be hereinafter more fully described, shown in the accompanying drawings, and particularly pointed out in the appended claim, it being understood that changes in the form, proportion, size, and minor details may be made within the scope of the claim without departing from the spirit or sacrificing any of the advantages of the invention.

In the drawings, Figure 1 is a central longitudinal sectional view of the outer end portion of an axle-spindle with the present hub-attaching device applied thereto. Fig. 2 is a side elevation of the nut, with a wrench in section, applied thereto and holding the locking parts in their unlocked positions. Fig. 3 is a transverse sectional view taken on the line 3 3 of Fig. 2. Fig. 4 is a detail perspective view of a hub-attaching nut constructed in accordance with the present invention.

Like characters of reference designate corresponding parts in all of the figures of the drawings.

To illustrate the present invention, there has been shown in the drawings an ordinary hub-attaching nut 1, which is provided in its outer face with a diagonal groove extending

from one corner to the opposite corner thereof for the reception of a locking-bar 2, which extends diametrically across the opening of the nut and is designed to take into a diametric groove formed in the outer end of the part to which the nut is applied—as, for instance, an axle-spindle 3. (Shown in Fig. 1.)

At one end of the locking-bar and projected at the inner side thereof there is a lateral heel 4, which is disposed at an obtuse angle with respect to the bar and comprising longitudinal angularly-related side pieces to embrace the adjacent corner edge of the nut. The adjacent edge faces of the nut are provided with transverse notches or grooves for the reception of the respective side pieces of the heel and producing a reduced rib 6 at the corner of the nut and embraced by the heel, there being a bowed or arcuate pivot-pin 7 passed through the opposite sides of the heel and the rib with its opposite ends upset against the heel, whereby the latter is pivotally connected to the nut. By having the reduced rib the sides of the heel are adapted to form continuations of the adjacent edge faces of the nut. A coiled spring 8 is seated in a notch or recess 9 at the back end of the rib and normally bears outwardly against the outer end of the heel, thereby yieldingly holding the locking-bar in the groove across the face of the nut, as shown in Fig. 1 of the drawings.

Upon reference to Fig. 2 of the drawings it will be seen that when an ordinary socket-wrench 10 is applied to the nut the jaws thereof will contact with the outwardly-projected heel portion of the locking-bar, thereby pressing said yieldable heel inwardly and throwing the locking-bar outwardly from the face of the nut, and thus permitting of the nut being screwed to place or removed. Immediately upon the removal of the wrench the spring will throw the locking-bar back into the groove in the face of the nut and also into the corresponding groove in the part to which the nut is applied, thereby locking the nut.

From the foregoing description it is apparent that the locking-bar is normally held yieldingly in its locked position and is thrown into an unlocked position by the application of a wrench thereto, so that when screwing

the nut in place the bar is maintained in its unlocked position and automatically snaps into locked engagement with the spindle when the wrench is removed. Also when the nut is upon the spindle and a wrench is applied thereto the bar is automatically thrown outwardly out of locked engagement with the spindle. Thus it does not require careful examination of the nut to unlock the same, and it may be readily applied and removed in the dark and in inconvenient places.

What is claimed is—

A nut, having a diagonal groove formed in the outer face thereof and extending from one corner to the opposite corner, one of the corners being reduced at one end of the groove, and there being grooves formed longitudinally at opposite sides of the reduced corner forming a rib, a locking-bar normally seated in the diagonal groove, and having a termi-

nal lateral heel comprising opposite longitudinal angularly-related side pieces embracing the rib and lying in the respective grooves, a pivot-pin passed through the opposite side pieces and the rib, and a spring interposed between the outer end of the heel and the rib to normally and yieldingly hold the bar in the groove with the heel projected beyond the peripheral edge of the nut, said heel being flush with the peripheral edge of the nut when the locking-bar is thrown outwardly upon its pivotal connection with the nut.

In testimony that I claim the foregoing as my own I have hereto affixed my signature in the presence of two witnesses.

WILLIAM E. WHITE.

Witnesses:

T. A. BELL,  
J. C. BELL.